



## INSTALLATION & MAINTENANCE INSTRUCTIONS MODEL DXP – PILLOW BLOCK BEARINGS

**WARNING!** Do not use fans in hazardous environments where the fan's electrical system could provide ignition to combustible flammable materials, unless built specifically for that environment. This unit has rotating parts and safety precautions should be exercised during installation, operation and maintenance.

Remove from shipping crate prior to installation. All debris and shipping material must be removed to prevent obstruction of airflow to and from the orifice. The orifice opening on both sides must be kept clear of obstructions. Failure to keep the orifice opening clear could cause undue stresses on the propeller blades, damage to the fan, and unsafe operation condition.

**WARNING!** Check voltage being supplied to fan to see that it corresponds with the motor nameplate voltage; high or low voltage can seriously damage the motor. On multi-voltage motors check motor terminal connections to make sure motor is internally connected for voltage being supplied. Motor wiring diagram is located on the side of the motor or in the motor wiring compartment. Leave enough slack in wiring to allow for motor movement when adjusting belt tension.

General contractor/customer is responsible to insure that the frameout dimensions are correct and adequate so that fan and cone clear all obstructions, which also include the fans/cones positioned in proximity. Fans are to be mounted to the structure per the installation instructions and all mounting points are to be secured or fastened to the structure to insure proper fan operation. General contractor/customer is also responsible to insure that fans/cones are protected from hazards that include, but are not limited to, snow falling from roof, snow load, and collision from farm implements. Acme does not accept responsibility for frameout mistakes, farm accidents, or any Acts of God.

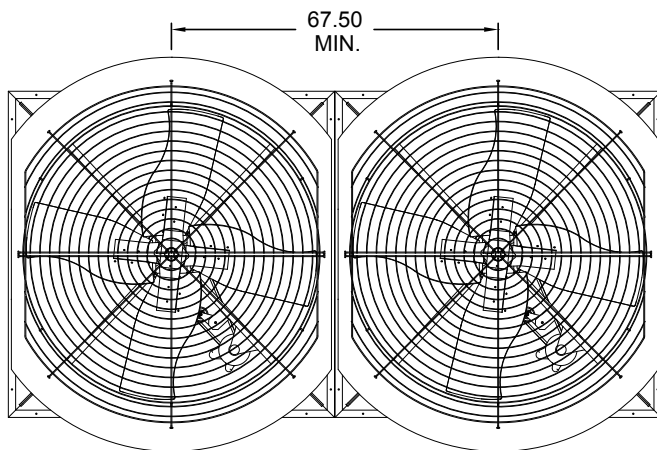

**ELLIPTICAL DIFFUSERS**

**FIGURE 1A**

Fans with elliptical diffusers can be mounted on 67.50 inch centers.

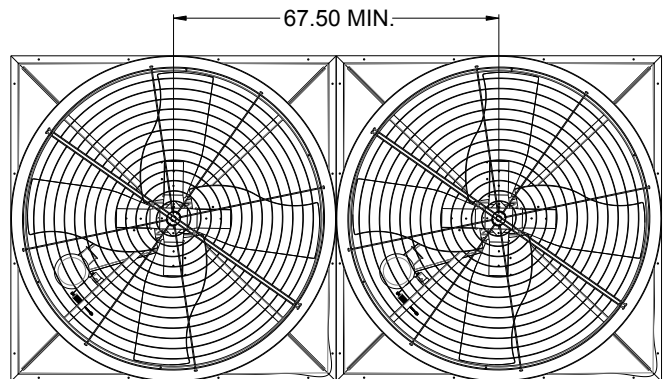

**ROUND DIFFUSERS**

**FIGURE 1B**

Fans with round diffusers can be mounted on 67.50 inch centers

## DXP COMPONENTS

CODE	DESCRIPTION	QTY
1	Propeller	1
2	Orifice Quarter Panel	4
3	Wall Attachment Bracket	4
4	Bearing Base	2
5	Bearing Base Support	2
6	Shaft	1
7	Bearing	2
8	Support Leg less Slots	3
9	Motor	1
10	Motor Support Leg	1
11	Brace	1
12	Motor Sheave	1
13	Belt	1
14	Fan Sheave	1
	Hardware	1

FIGURE 2

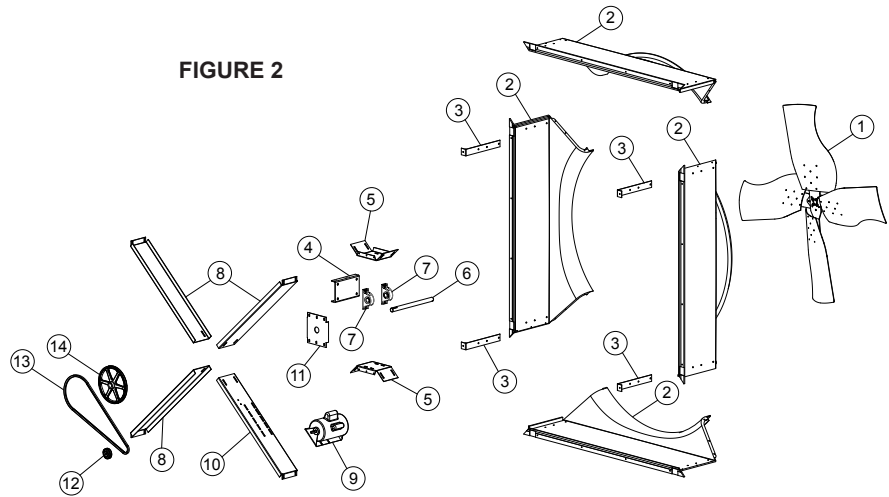

## ROTARY BELT TIGHTENER MAINTENANCE

**CAUTION:** Before proceeding, make sure electrical service to fan is locked in "OFF" position.

1. If the belt stretches enough that the belt tightener does not keep the belt tight, the belt tightener can be adjusted. Start by loosening the 3/8 inch bolt holding the belt tightener to the belt tightener base.
2. Place a wrench on the hex nut in the belt tightener body as shown in Figure 3 and a wrench on the belt tightener mounting fastener.
3. Using the wrench on the belt tightener body, apply pressure in the appropriate direction (see Figure 3) until the belt is properly tensioned. Note: The belt tightener body has marks on it as shown in Figure 4 representing degrees. The proper alignment after tightening the mounting bolt is shown in Figure 5.
4. With the belt tightener securely held in position, tighten the belt tightener mounting bolt.

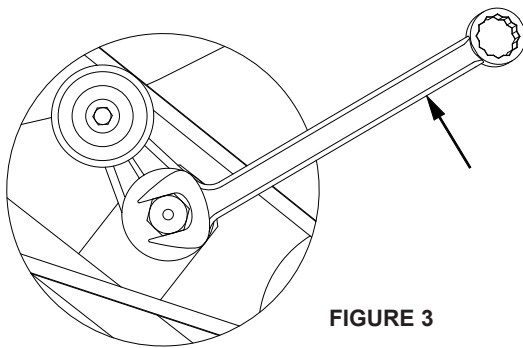

FIGURE 3

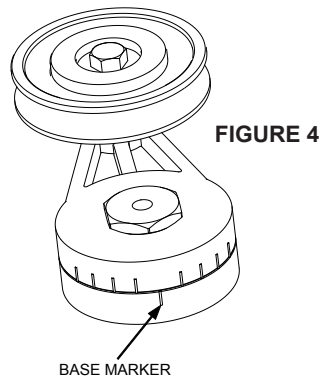

FIGURE 4

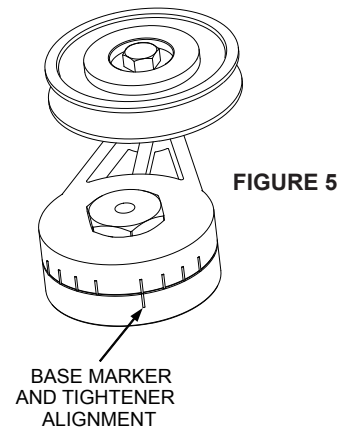

FIGURE 5

BASE MARKER  
AND TIGHTENER  
ALIGNMENT

## SPRING TYPE BELT TIGHTENER /INSTALLATION/MAINTENANCE

**Note:** Spring Type belt tensioners must be field installed. These are not shipped on the fan.

1. Shut off power to the fan.
2. Remove the belt and motor. Note: The motor mounting bolts will be used to mount the belt tightener.
3. Mount the belt tightener top to the motor and the belt tightener bottom to the fan motor base as shown in Figure 6 and Figure 7 using the motor mounting bolts. Mount the belt tightener bottom to the motor base in the same slots in the motor base that the motor was mounted in.
4. Mount the motor to the fan by aligning the hinge holes of the belt tightener top and bottom and inserting the hinge pin. Secure the hinge pin with the hitch pins as shown in Figures 6 and 7.
5. Install the long bolt and spring as shown in Figure 6 and Figure 7 in the front hole of the motor. Tighten the spring to a length of 1.75 inches as shown in Figure 7.
6. If the belt stretches in the future enough that the belt tightener is not working, loosen the bolts holding the belt tightener base and move the motor assembly to the right.

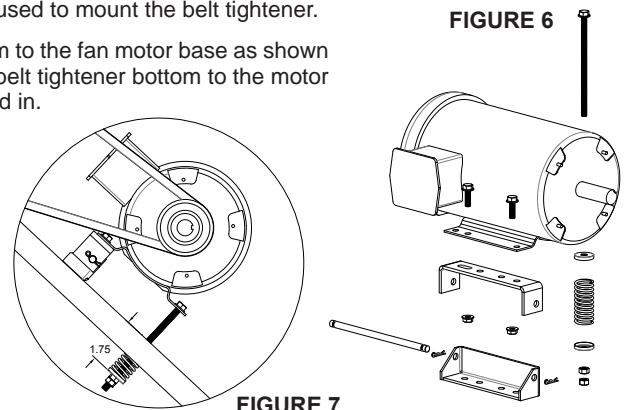

FIGURE 7

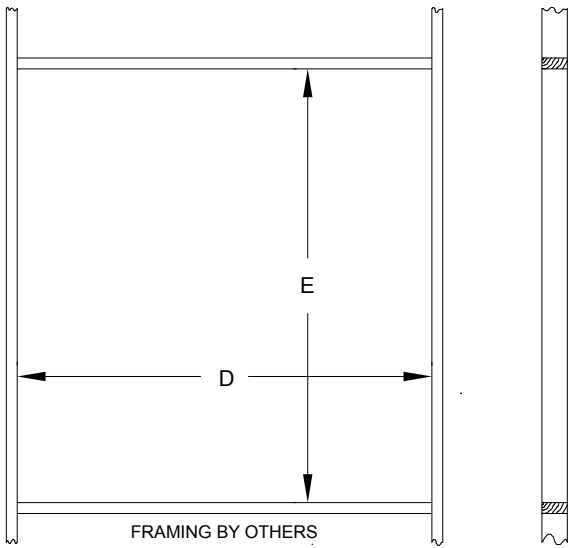

FIGURE 8

**INSTALLATION IN WALL**

Provide an opening in the wall of the building as shown in Figure 8 using the D and E dimensions shown in the table below.

A distance of at least four and one-half feet (4 ½') should be allowed between the fan inlet or discharge opening and any adjacent wall or large obstruction.

**SPECIAL NOTE:** *Attach the fan to the inside of the wall opening using lag bolts provided by others. Also place lag bolts through the wall attachment brackets into the wall to secure the frame assembly to the wall for additional stability. See Figure 8.*

**CAUTION!** Guards are strongly recommended when the fan is installed within eight (8) feet of the floor, working level or within reach of personnel. Guards complying with OSHA regulations are available as optional equipment. Review OSHA Codes and obtain a quotation.

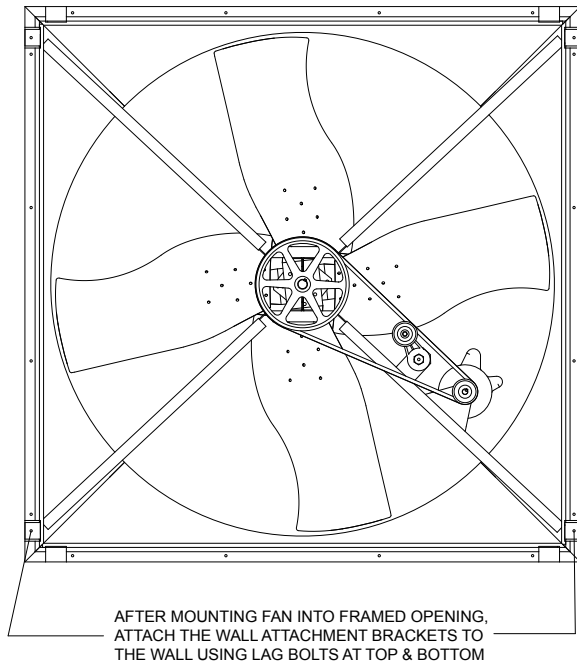

FIGURE 9

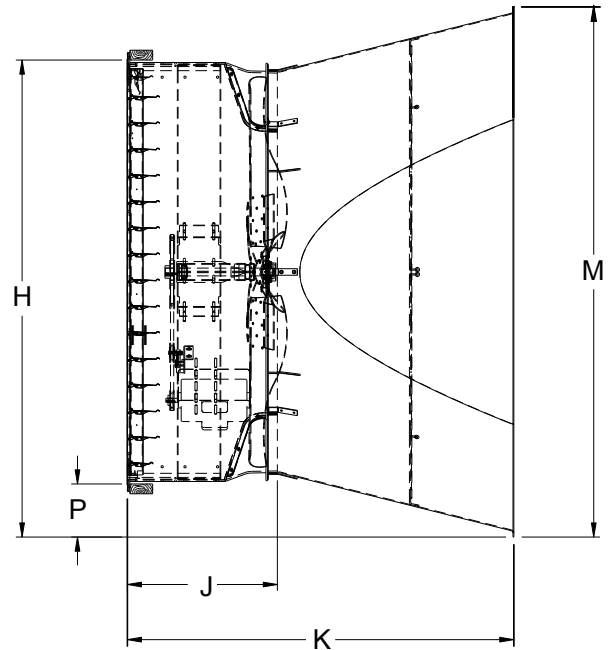

FIGURE 10  
ELLIPTICAL DIFFUSER

FAN	E		D		Elliptical Diffusers				J		K		Elliptical Diffusers		Round Diffusers	
					H		P						M		M	
	IN	mm	IN	mm	IN	mm	IN	mm	IN	mm	IN	mm	IN	mm	IN	mm
DXP60	65.13	1654	65.13	1654	73.07	1856	7.94	202	23.5	597	59.00	1499	81.00	2057	67.5	1715

## CONE INSTALLATION

1. Locate the cone mounting brackets as shown in Figure 11.
2. Install the cone mounting brackets on the fan in eight places as shown in Figure 11 using the  $\frac{1}{4} \times 1 \frac{1}{4}$  self drilling Tek screws provided. Brackets should be mounted at the top, bottom, both sides and next to the joints of the housing sections as shown in Figure 11.
3. Attach the brackets by placing the base of the bracket against the reinforcing ring around the orifice with the edge of the bracket against the edge of the reinforcing ring. Using the  $\frac{1}{4} \times 1 \frac{1}{4}$  self drilling Tek screws provided, attach the bracket to the reinforcing ring.
4. Repeat item three with the next seven brackets.
5. Install the cone over the orifice with the fat sides of the cone parallel with the side of the fan.
6. Using the  $\frac{1}{4} \times 1 \frac{1}{4}$  self drilling Tek screws provided, insert a screw thru the upper hole in one cone mounting bracket and screw into the cone to hold it in position. Insert a screw through the lower hole. Continue until all cone mounting brackets are secured to the cone as shown in Figure 12.
7. Connect the two guard half sections with plastic wire ties spaced evenly along the junction as shown in Figure 13.
8. Slide guard into cone maintaining a vertical placement (as shown in Figure 12) until the eyelets contact the cone at all points.
9. Mark at least four eyelet positions on the cone. Remove the guard and drill .281 diameter holes at the marked points.
10. Install the guard by using  $\frac{1}{4}$ -20 x 1 stainless steel bolts and nuts provided in the four drilled holes.
11. Drill the remaining eyelet holes and install the  $\frac{1}{4}$ -20 x 1 stainless steel bolts in the holes.

FIGURE 11

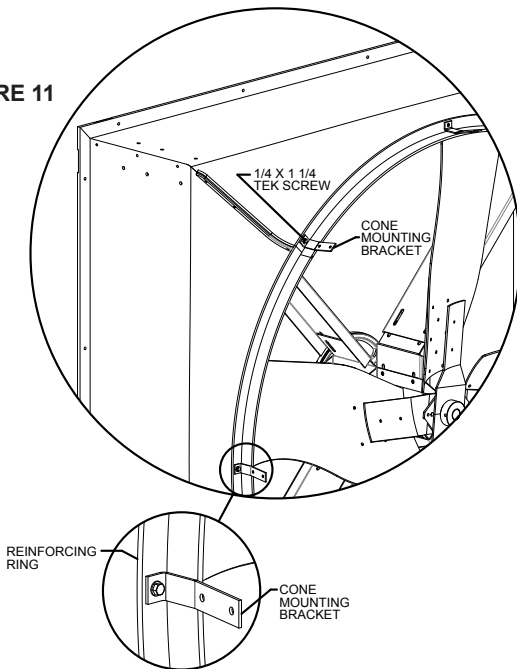

FIGURE 12

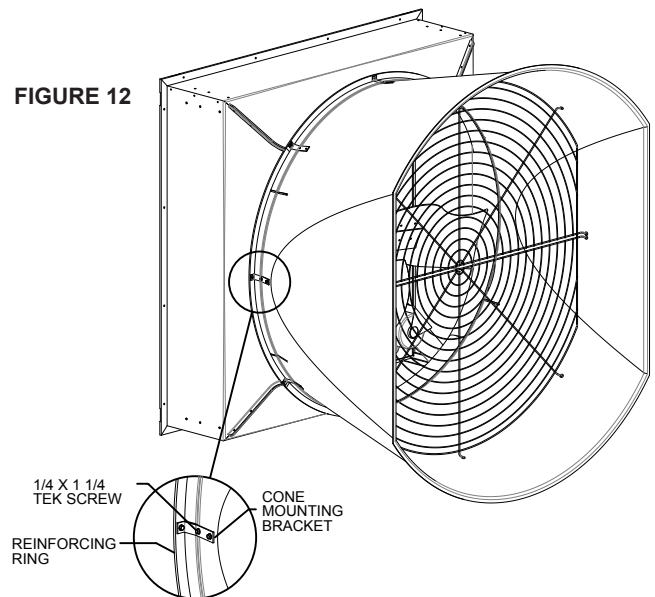
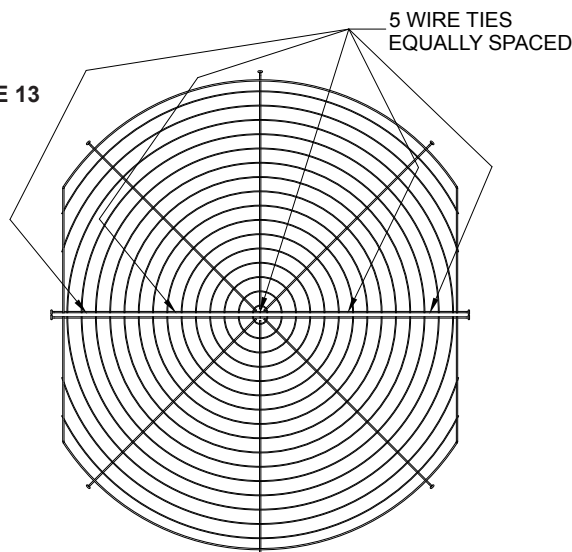

FIGURE 13



## MAINTENANCE

1. Motors supplied by Acme have prelubricated bearings. Consult information printed on motor for lubrication instructions.
2. Grease
  - a. Most of the pillow-block bearings used on Acme fans have a grease zerk or port for zerk fitting to lubricate the bearing. It is suggested that this zerk be greased 4 times a year.
  - b. **Suggested Grease type** - Lubrimatic White Lithium Grease part number 11354 or equivalent white lithium grease meeting ISO 6743/9:1987 standard.
  - c. **Grease volume** – It is recommended that 1 gram (+/- 10%) of grease be applied at each maintenance interval.
  - d. **Grease gun** – the standard grease gun producing no more than 6000 psi is recommended for this application. Most dispense an average of .75 grams to 1.25 grams per stroke, but it is up to the consumer to determine the volume/stroke of the grease gun you prefer and lubricate accordingly.

**Warning! Do not operate at higher speeds than rated. Do not replace motor pulley with a larger diameter pulley. Do not replace the fan pulley with one smaller in diameter. The pulley ratios are set so that the motor will not be overloaded.**

3. Check belt tension after first 48 hours of operation and annually thereafter. Belt should depress its width when pressed firmly inward at midway point between the pulleys. Too much tension will damage bearings; belt should be tight enough to prevent slippage. When replacing worn belt, replace motor pulley if “shoulder” is worn in groove.
4. If motor requires replacement, one comparable to the original with the same service factor and enclosure must be used.
5. If pillow-block bearings need replacement, replace with bearings comparable to the original equipment. Shaft measurements should be taken before disassembly to insure proper shaft position in the bearings. Tighten all mounting bolts and set screws during installation of new bearings.
6. The customer/building engineer/architect is responsible for ensuring the structural integrity of the supporting wall. The wall supporting fans should be rigid enough to not only support the mass of the fan assemblies, but also stiff enough to impede any natural harmonic frequencies and pressures created by rotating mechanical devices, such as fans.
7. **Cleaning on or near Bearing Housing, Bearings, and Fan Shaft** – It is recommended that the bearing housing, bearings, and fan shaft **NEVER** be pressure washed or premature bearing failure may be induced. The soiled bearing housing should be brushed clean with a stiff bristle brush, then a light coat of Simple Green spray cleaner applied, allowing to soak for 30 seconds, and wiping away cleaning residue with a clean dry cloth. At this time, check to make sure all bolts in the bearing housing are secure. **After cleaning and washdown, let the fans run for 4 hours to properly dry.**

## SET SCREW TIGHTENING SCHEDULE

1. Before initial operation of the fan, tighten set screws according to the procedure outlined below.
2. After 500 operating hours or three months, whichever comes first, tighten set screws to the full recommended torque.
3. At least once a year, tighten set screws to the full recommended torque.

### PROCEDURE FOR TIGHTENING SET SCREWS IN BEARINGS AND HUBS

#### One Set Screw Application

Using a torque wrench, tighten the set screw to the torque recommended in the table below.

#### Two Set Screw Application

1. Using a torque wrench, tighten one set screw to half of the torque recommended in the table below.
2. Tighten the second set screw to the full recommended torque.
3. Tighten the first set screw to the full recommended torque.

**Table 1. Recommended Tightening Torque for Set Screws**

Set Screw Diameter	Torque (in-lbs)
#10	35
1/4	80
5/16	126
3/8	240
7/16	384
1/2	744
9/16	1080
5/8	1500
3/4	2580
7/8	3600
1	5400

## VARIABLE FREQUENCY DRIVES AND MOTORS

There are occasions when a Variable Frequency Drive (VFD) will cause poor motor performance and possible damage. To avoid these problems, the Company recommends the following:

1. Select compatible motor and VFD inverter; if possible, the motor and the inverter should be from the same manufacturer or at least the inverter selected should be recommended by the motor manufacturer.
2. A motor certified for VFD operation must be used. Operation of a motor with TOL should not be used with VFD's.

**NOTE: The Company will not honor motor warranty claims if the customer fails to follow these recommendations.**

