



ACME ENGINEERING & MANUFACTURING CORP.

P.O. Box 978 • Muskogee, OK 74402

918/682-7791 Fax: 918/682-0134

www.acmeag.com • www.acmehort.com

acmeag@acmefan.com • acmehort@acmefan.com

Form 610676

January 2005

OWNERS MANUAL • INSTALLATION INSTRUCTIONS

MODEL CTPP

6" Kool-Cel® Closed Top Plastic Pipe Cooling System

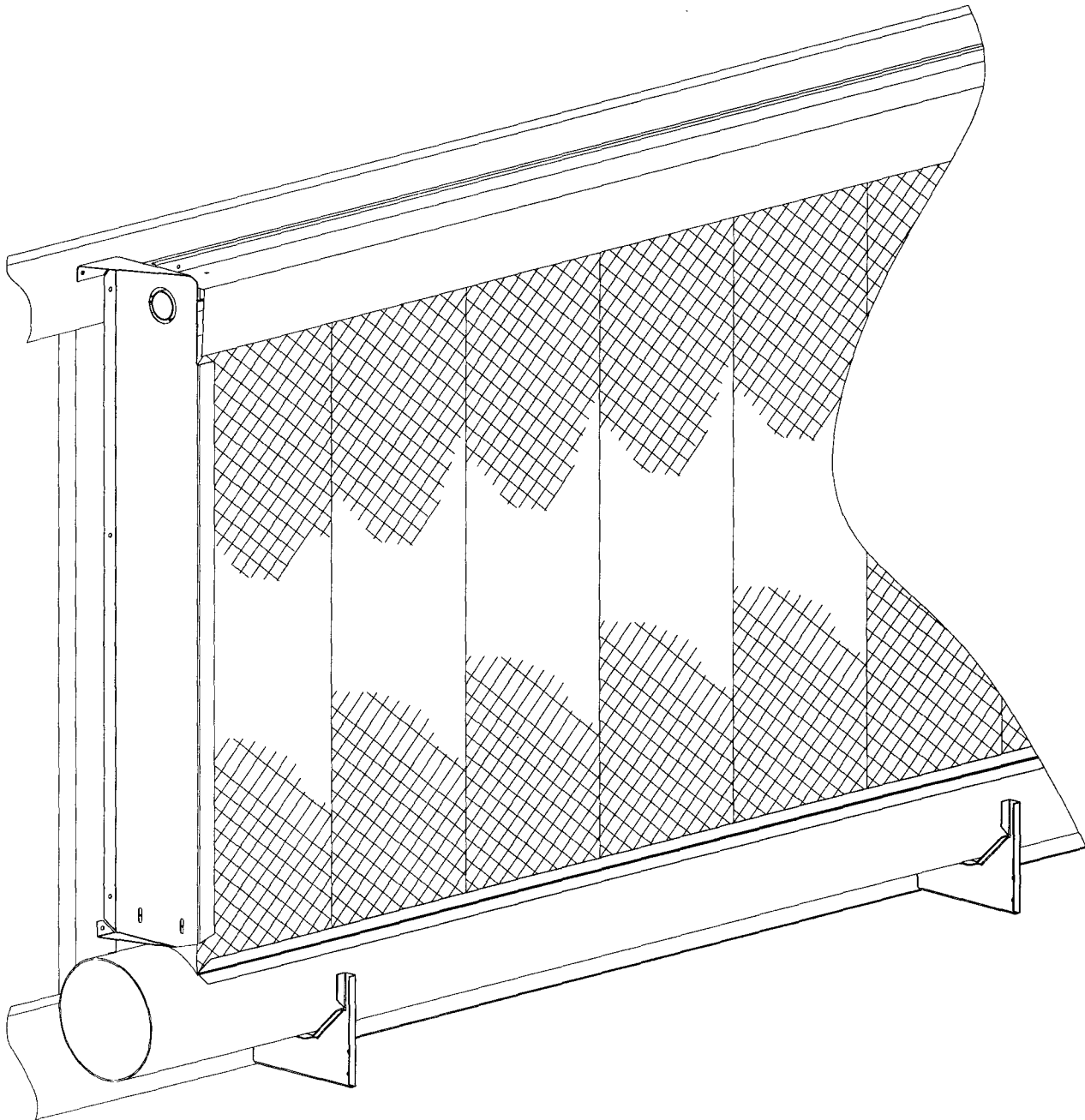

TABLE OF CONTENTS

Section	Page
I. Components.....	2
II. Building Preparation	2-4
III. Installation of System.....	4-10
IV. Plumbing Installation	11
V. Exploded Drawing of System Plumbing	12
VI. 8" PVC Transition Pump Tank (Optional).....	13
VII. PT50-OTP 50 Gallon Pump Tank Kit (Optional).....	13
VIII. Start Up and Testing.....	14
IX. Maintenance	14-15
X. Pad Care	15
Warranty.....	16

I. Components

A. Standard Kool-Cel components provided by Acme:

1. Kool-Cel pads 6" x 12" x 24", 36", 48", 60" or 72" .
2. Water Pump.
3. Distribution and return system. Available in 5' systems to 80' systems. Includes distribution pipe, top assembly, pad support assembly, pipe gutter, and support brackets.
4. Plumbing Kit.

B. Optional Kool-Cel Components provided by Acme upon request:

1. End Cover Package.
2. Water Valves with Float Control.
3. 8" PVC Transition Pump Tank
4. PT50-OTP 50 Gallon Pump Tank Kit.

C. Provided By Owner or Others:

- Framing material.
- Sump Tank, drain and cover.
- Water Supply to float valve.
- Return pipe from downspout to sump and filter.

II. Building Preparation:

A. Location of Pad System: Typical Pad/Fan Relative Locations.

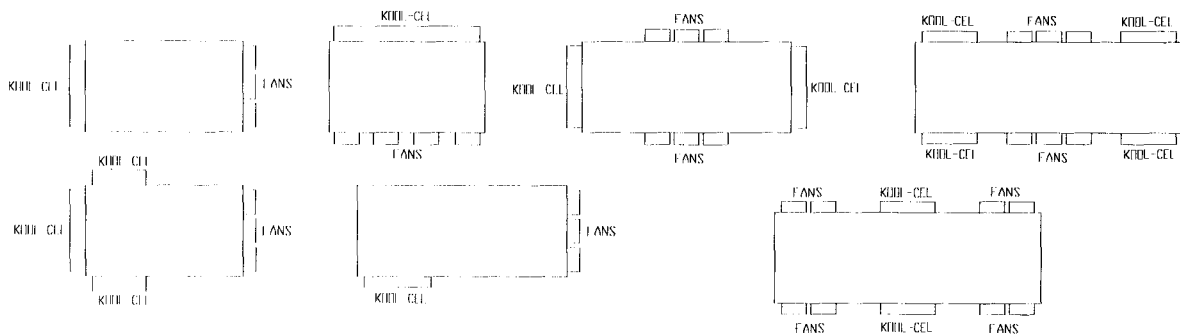

The Kool-Cel pad should be placed away from the fans (opposite) so that the cooled air can flow through the building without turbulence as shown in Figure 1. Pads should be no more than 250' from the fans in greenhouse buildings to avoid excessive temperature rise and velocities.

In a **greenhouse**, the top of the pad should be near the top of the crop or have its midpoint centered on the midpoint of the crop.

In **poultry and livestock** installations, the pad is generally placed on the outside of the building so that the top of the pad is not below the highest desired level. An eave extending beyond the CTPP system is recommended.

B. Framed Opening and Sizes

Note: The side wall structural members should be left intact as shown in Figure 2.

C. Stringers – The framing and support stringers could be any type of material (metal channels, square tubing, treated wood, etc.). The design should provide a flat surface for mounting support brackets and the lower stringer should be capable of carrying a load of 4.11 lbs. per sq. ft. of pad. All framing in this manual refers to treated wood. The framed opening must be vertical and square for proper installation of the system. The use of a chalk line during stringer installation will aid in keeping the system square.

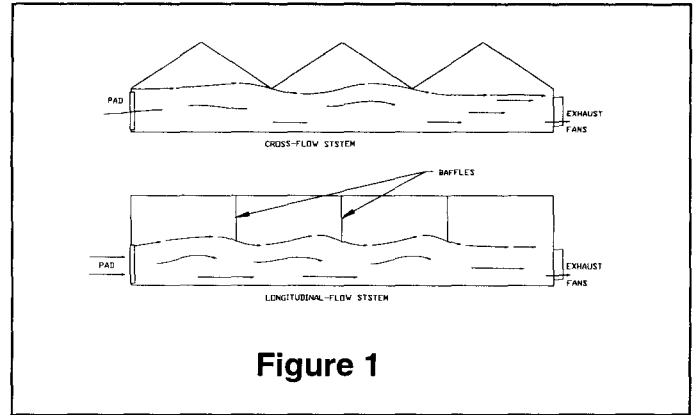
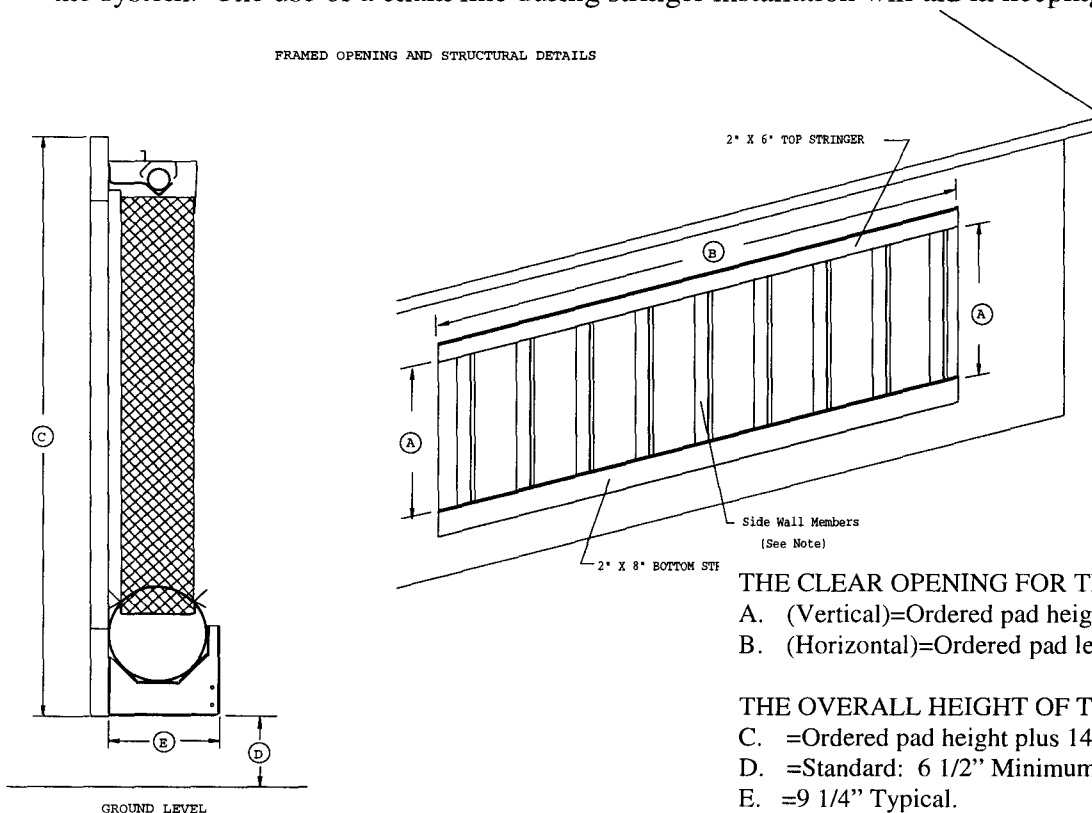

Figure 1

FRAMED OPENING AND STRUCTURAL DETAILS



THE CLEAR OPENING FOR THE PAD SYSTEM IS:
 A. (Vertical)=Ordered pad height + 1".
 B. (Horizontal)=Ordered pad length.

THE OVERALL HEIGHT OF THE SYSTEM:
 C. =Ordered pad height plus 14".
 D. =Standard: 6 1/2" Minimum for "T" Tank.
 E. =9 1/4" Typical.

Figure 2
 (Framed Opening Layout)

D. Optional 8" PVC Transition Pump Tank – See Page 13.

III. System Installation

After installing all framing materials, the Kool-Cel distribution and return system will go together simply and quickly following the instructions step by step.

HINTS:

Framing - If framing is not properly installed as shown in the Installation Instructions, the system will not operate properly. Refer to Section II.B. and Figure 1 to verify the framing has been installed accurately.

Caulking - Where the installation instructions refer to caulking, use the Butylgrip caulking supplied with the CTPP Kool-Cel System unless otherwise specified.

Packages - Place all cartons in the area of installation and open the top of the cartons. **Do not remove the material until needed.** NOTE: The packing slips and Installation and Maintenance Instructions should be retained for future reference.

A. Gutter Installation

1. Pipe Support Bracket

- A) To locate the pipe support bracket position on the bottom stringer for the 8 inch pipe, refer to chalk line shown in Figure 3. The chalk line should be 3" down from the top of the bottom stringer and run its full length. The chalk line will be used to locate the top hole position of the brackets. Hole spacing is shown in Figure 3 and Figure 4.

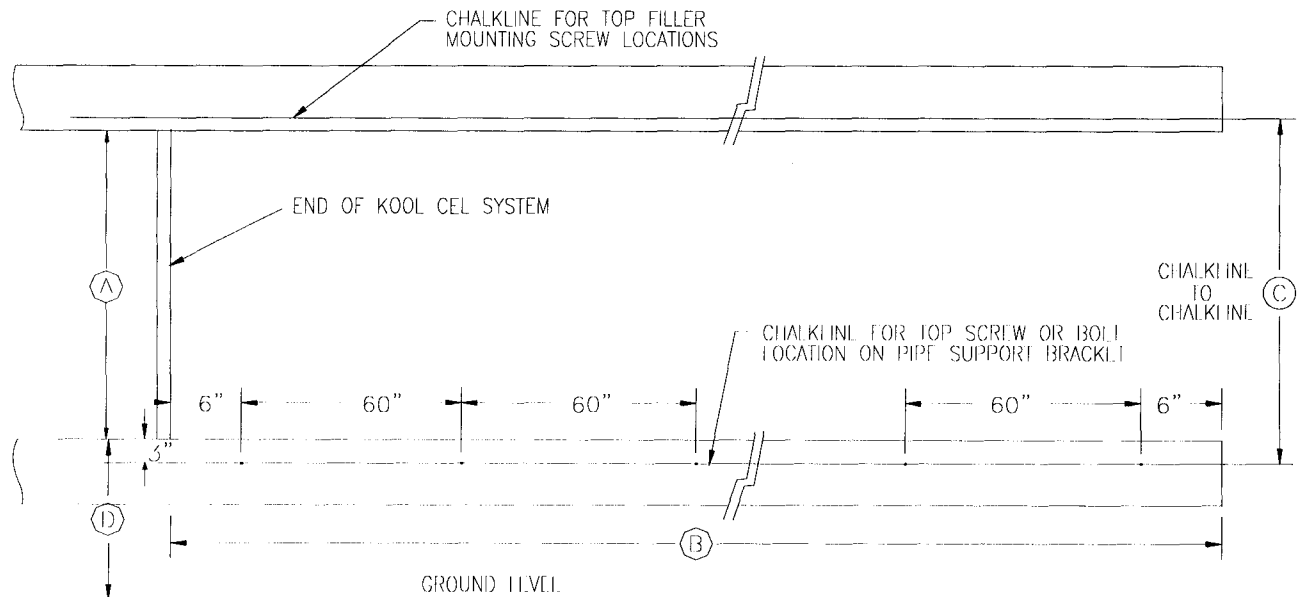

Figure 3

- A= Ordered Pad Height + 1"
B= Ordered Pad Length
C= Ordered Pad Height plus 6 9/16"
D= Minimum dimension is 14"
(Ground level to top of lower stringer.)

- B) Locate the box containing the pipe support brackets. Install all pipe support brackets as shown in Figure 4, making sure brackets are vertical. Note: The bracket's top hole should be on the chalk line. Lag screws are shown. They are to be used if going into the 2x8 material at a 4x4 post location. If going into the 2x8 material at a location other than the 4x4 post, use the 1/4" x 2 1/2" bolts, washers and nuts.

WARNING FOR TREATED LUMBER

The new ACQ treated wood should be used with Hot Dip Galvanized coated fasteners or Stainless Steel fasteners. Aluminum should not be used in contact with ACQ treated wood. All galvanized electroplated metal should be isolated from the treated wood by builders felt and fastened with approved fasteners.

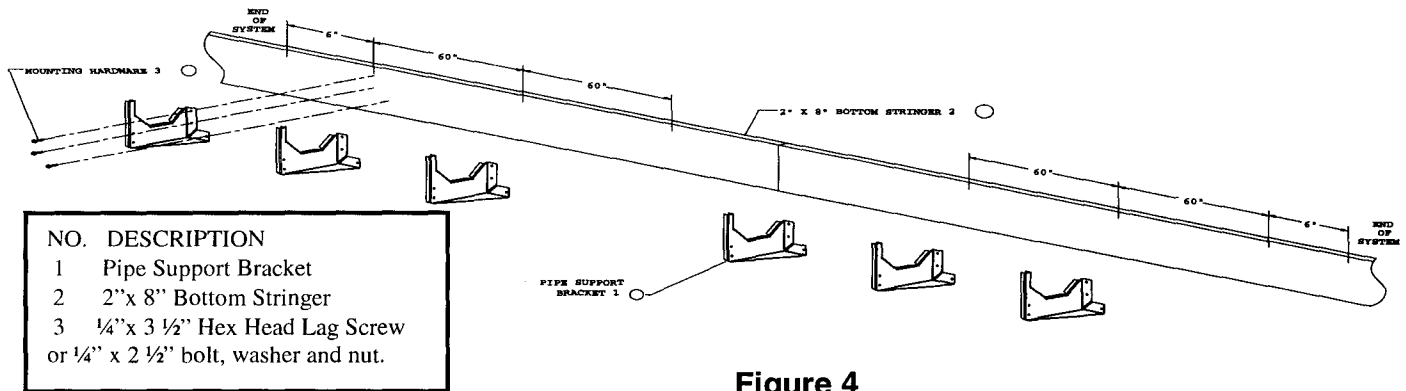

Figure 4

2. Pipe Installation

- A) The shipping containers (8" PVC pipe) of the 5' and 10' sections of the CTPP system are to be used as gutter sections.
- B) Locate these gutter sections and lay them out along the length of the framed opening with the belled end toward the end of the system opposite the pump tank. Remove the contents of the gutter and set these parts aside.

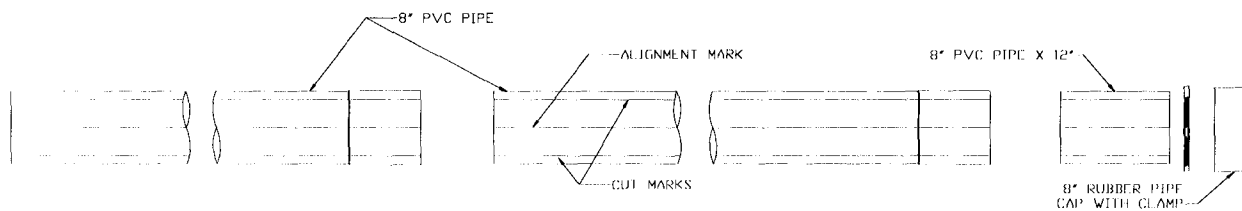

Figure 5

- C) Locate the 12" long section of pipe (shipped only with systems of 10' increments – 30, 40, etc.) and 8" pipe cap that can be found in the same shipping container as the pipe support brackets. These parts are to be located at the end of the system opposite the pump tank.
- D) These pipes are marked with three lines. The 8 inch pipe sections are to be glued together with the lines aligned from one pipe to another as shown in Figure 5. Using the PVC cleaner and cement supplied with the system (one quart container), glue all the 8 inch pipe sections together as shown in Figure 5 making sure the alignment marks are aligned.
- E) Install the 8 inch rubber pipe cap and clamp on the end of the 12 inch section of 8 inch pipe as shown in Figure 5.

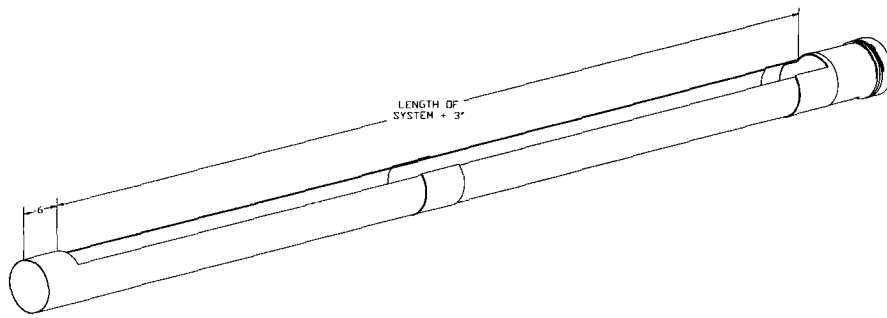

Figure 6

- F) Mark the pipe between the two outer marks approximately 6 inches from the open end of the pipe as shown in Figure 6. Make a second mark on the pipe between the two outer marks a distance equal to the length of the system plus 3 inches. Using a skill saw or jig saw, cut along the inside of the outer marks from one end mark to the other leaving the mark to the outside of the pipe as shown in Figure 6. Cut along the end marks to complete the cut and remove the cut portion of pipe.
- G) Place the entire pipe assembly on the pipe supports as shown in Figure 7. The end of the cut opening in the pipe on the pump end should be 12 inches from the first pipe support as shown in Figure 4.

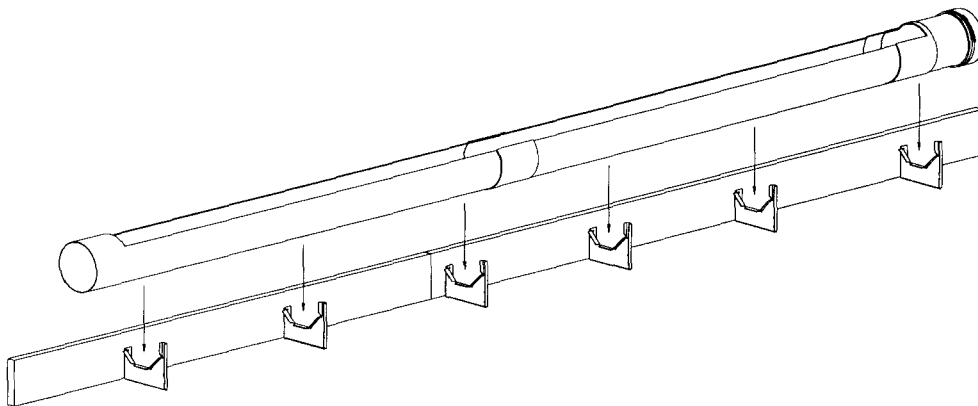

Figure 7

- H) Locate the pad supports and slip the pad supports together as shown in Figure 8 and 9. Leave 6 inches between the pad supports for the Kool Cel pads.

Figure 8

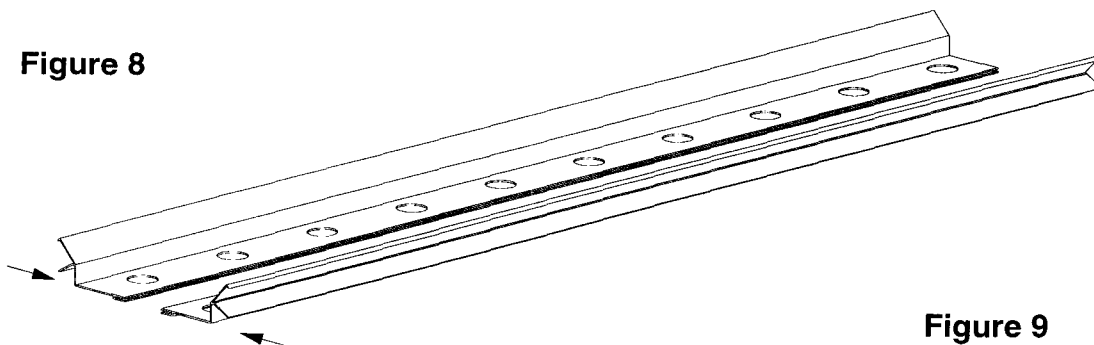
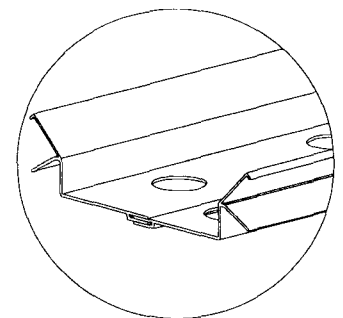

Figure 9



- I) Locate the pad support connectors and slip the pad support connectors on all pad supports except the first pair as shown in Figure 10 and Figure 11.

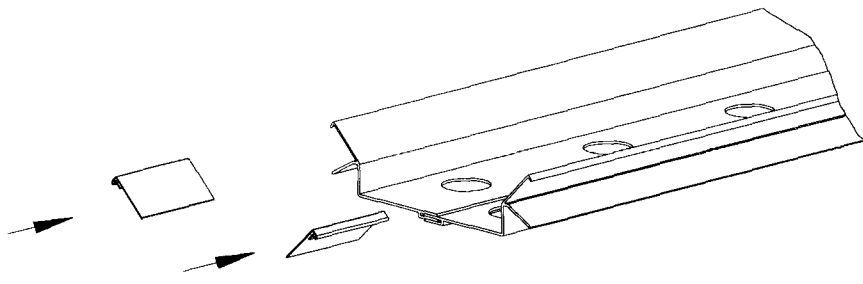

Figure 10

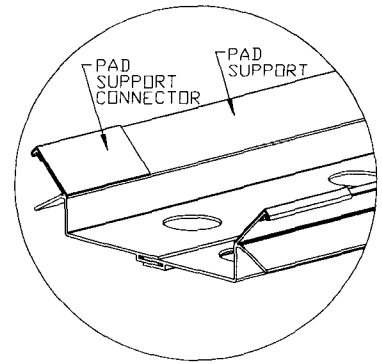

Figure 11

- J) Place the pad support assemblies into the cut 8 inch pipe as shown in Figure 12. Slide the pad support connectors onto the adjacent pad supports. The pad support connectors should set halfway on each pad support as shown in Figure 13.

Figure 12

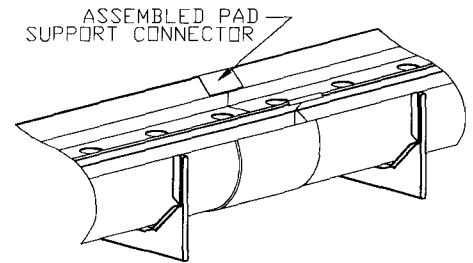
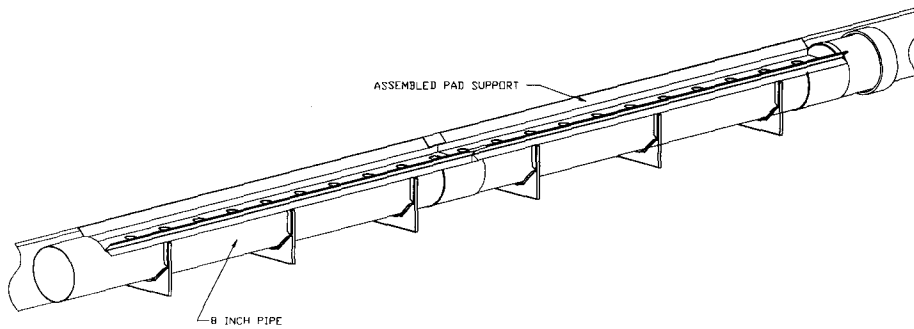

Figure 13

retainers

B. System Top Installation

1. Beginning at the pump end of the system, locate the position of the end of the system (end of system is end of pad support in gutter) and install the top cover support sections and the pipe hangers to the top stringer by lining up the top holes of the top cover support sections with the chalkline (refer to Figure 3) on the top stringer. Attach the hangers and the top cover support sections to the stringers with $\frac{1}{4}$ " x $1 \frac{1}{2}$ " hex head screws as shown in Figure 14.

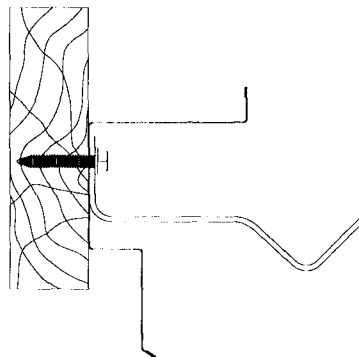

Figure 14

2. Caulk the top cover support sections at the seams between the top cover support sections as shown in Figure 15.

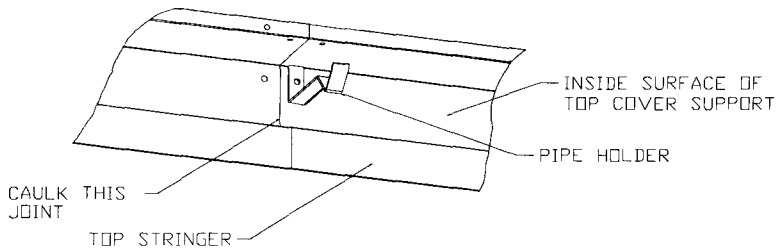
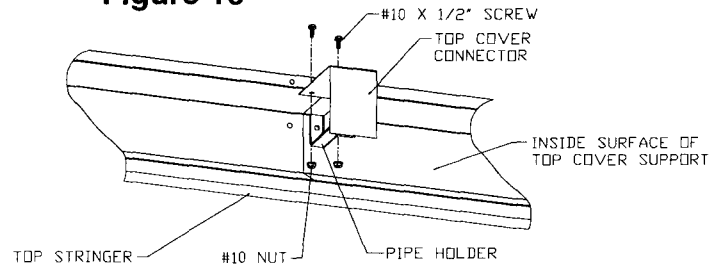
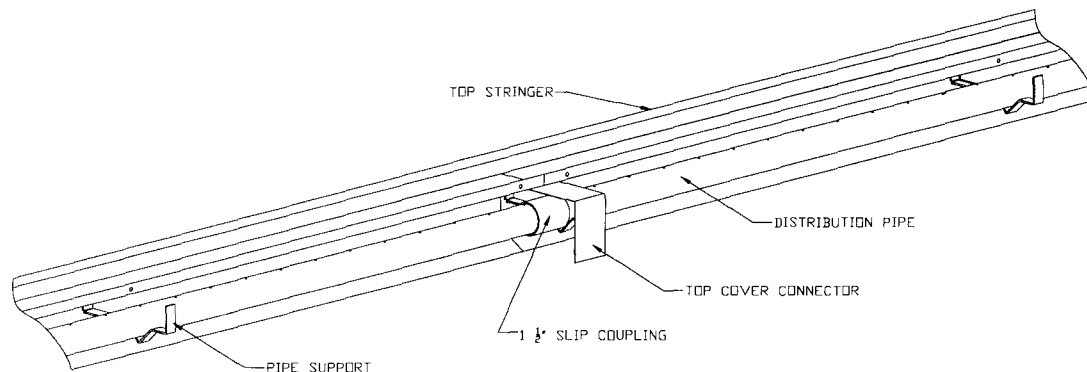

Figure 16



3. Center the top cover connectors over each seam as shown in Figure 16 and attach with #10 x 1/2" screws.
4. Place a 10' section of 1 1/2" pipe WITH THE METERED HOLES UP into the pipe hangers at the pump end of the Kool-Cel system. Enough pipe should extend beyond the top cover support as shown in Figure 17 to later attach a pvc pipe connector for plumbing installation.

FIGURE 17



5. Install a 1 1/2" slip joint coupling to the end on the pipe opposite the pump and assemble another 10' section of pipe. **DO NOT USE PVC CEMENT ON THESE JOINTS.** The coupling and pipe should be pushed tightly together **BUT NOT CEMENTED.** **MAKE SURE THE METERED HOLES ARE AT THE TOP SO THE WATER WILL SPRAY DIRECTLY UPWARD FOR PROPER WATER DISTRIBUTION.**
6. Install the remaining pipe using the 1 1/2" couplings (no cement), always making certain that the metered holes point directly upward. Again, the pipe should extend beyond the opposite end to later attach a 1 1/2" tee for installation of the bleed-off and clean-out assembly.

C. Top/Pipe Cover and Pad Installation

Note: Install the pads before installing the top cover. (Installing pads with the top cover in place could result in pad damage and "springing" of the top cover which could result in improper channeling of the water).

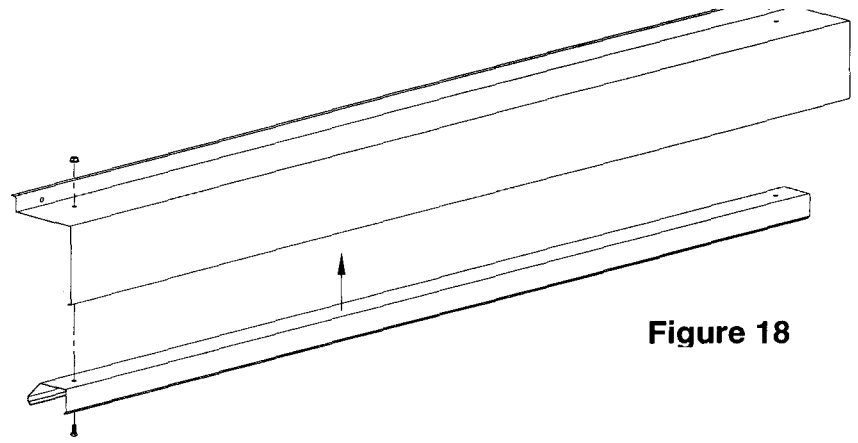
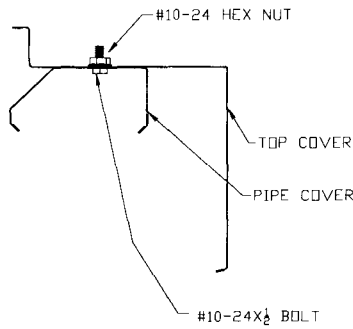
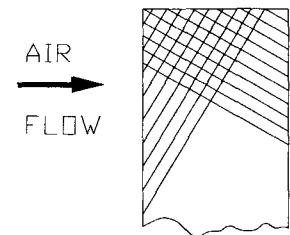

Figure 18

1. Beginning at the pump end of the Kool-Cel system, install the end section of the top cover assembly with #10-24 x 1/2" bolts and nuts provided. The pipe cover should be assembled to the top cover as shown in Figure 21.
2. Continue installing top/pipe cover sections until complete. Top cover connectors should match the joints of the top/pipe cover sections to prohibit leaks between the joints.

Figure 19

3. Place the bottom of the pad firmly on the drip collector and under the pipe. **THE 6 INCH PADS MUST BE INSTALLED AS SHOWN IN FIGURE 19 WITH THE HIGHER ANGLE OF THE FLUTES POINTING UPWARD AND TOWARD THE BUILDING.** (If you can see through the flutes you should be looking at the ceiling of the building.)



4. **NOTE: Pad width is not always 12 inches. The last pad should not be installed at the end and may need to be trimmed to fit easily into the available space. Place at least two pads into the end of the system leaving room for the last pad as shown in Figure 20. To install the last pad, measure the opening for the last pad and trim to fit the opening. DO NOT force the last pad into a space that is smaller than the pad.**

Figure 20

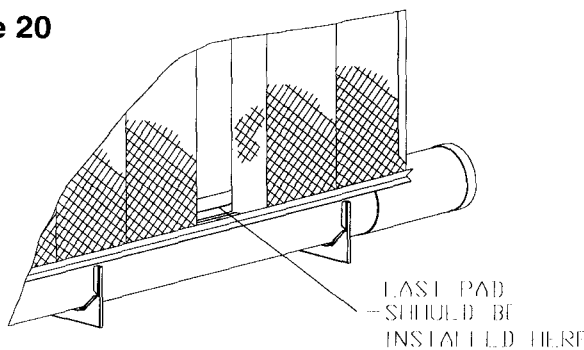
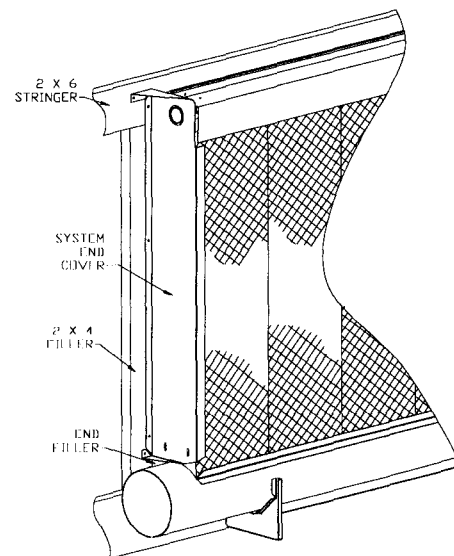

Figure 21



D. System End Cover Installation (Optional)

1. The system end covers attach to the stringer and to a 2" X 4" filler in the wall mounted between the top stringer and bottom stringer with the inside of the 2" x 4" at the end of the Kool-Cel system as shown in Figure 21. Install a 2"x 4" filler between the top stringer
2. Install the end filler (Figure 22) to cover the opening between the system end cover and the 8 inch pipe.
3. Locate the two system end covers as shown in Figure 21. Slip the hole in the system end cover over the distribution pipe and fasten the system end cover to the filler and stringers as shown in Figure 21

using the 1/4" x 1 1/2" screws provided. The system end cover should be placed against the top cover support such that there is no gap between the system end cover and the top cover support. If the Kool-Cel pad extends beyond the top cover support, water could splash out between the gap created between the top cover and the system end cover (see pad installation Item D-3).

4. Caulk the area around the pipe on the system end cover as shown in Figure 23 to eliminate any water leakage.
5. Attach the end filler to the system end covers as shown in Figure 21 using the #10 x 1/2 inch screws provided.

FIGURE 22

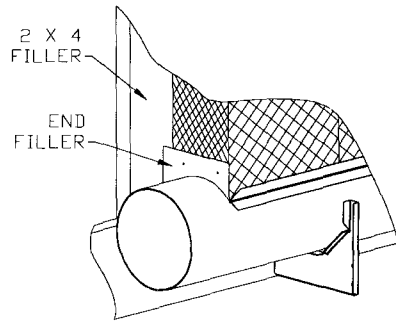
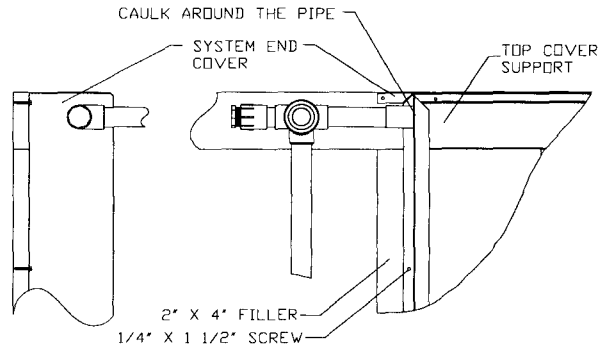

FIGURE 23



E. Bleed-Off Assembly Installation

Locate the bleed-off end opposite the supply line (or drain). Locate the parts outlined in Table 1 and install in the numbered sequence shown. Cement the pipe and fittings but **DO NOT** cement the threads of the female adapter or the male threads of the plugs. Allow at least one hour drying time for the cement.

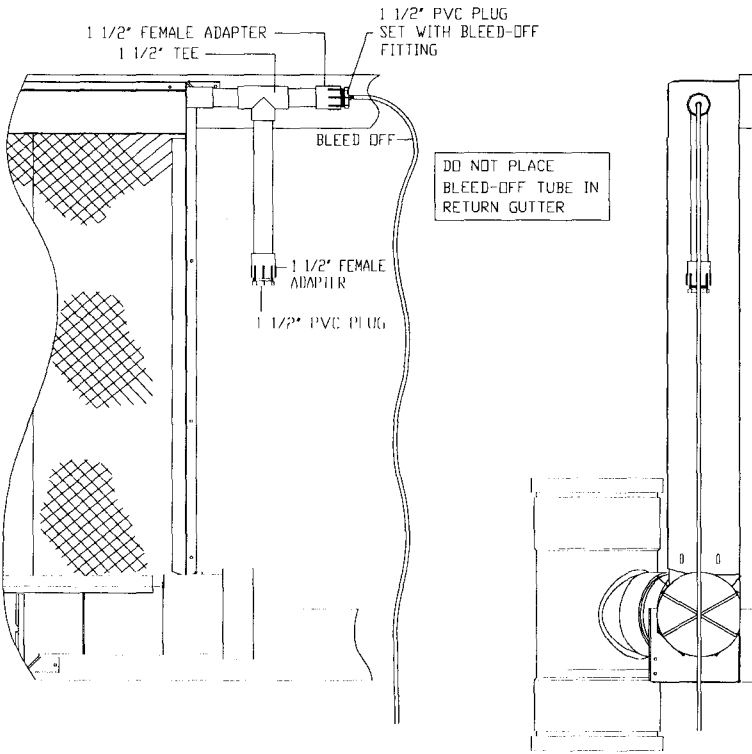

TABLE 1

ITEM	DESCRIPTION	QTY
1	1-1/2" Tee	1
2	2'4" Piece of 1-1/2" Pipe	1
3, 6	1-1/2" Female Adapter	2
4	1-1/2" Plug	1
5	Short piece of 1-1/2" Pipe	1
6	See Above	
7	1-1/2" plug set with bleed-off tube fitting	1
8	Bleed-off Tube	1

DO NOT PLACE BLEED-OFF TUBE IN RETURN GUTTER OR WATER SUPPLY TANK.

Figure 24

IV. Plumbing Installation

A complete plumbing kit is available through your distributor. Extra items are included in this kit so that one kit may fit all installations. If you have not purchased this kit, refer to Figures 25 and 26 for items required. Assemble the plumbing as shown in Figures 25 and 26 after the system has been installed.

Note: Provide a water supply capable of supplying .75 gal per minute per linear foot of pad.

**Figure 25
DRAIN END**

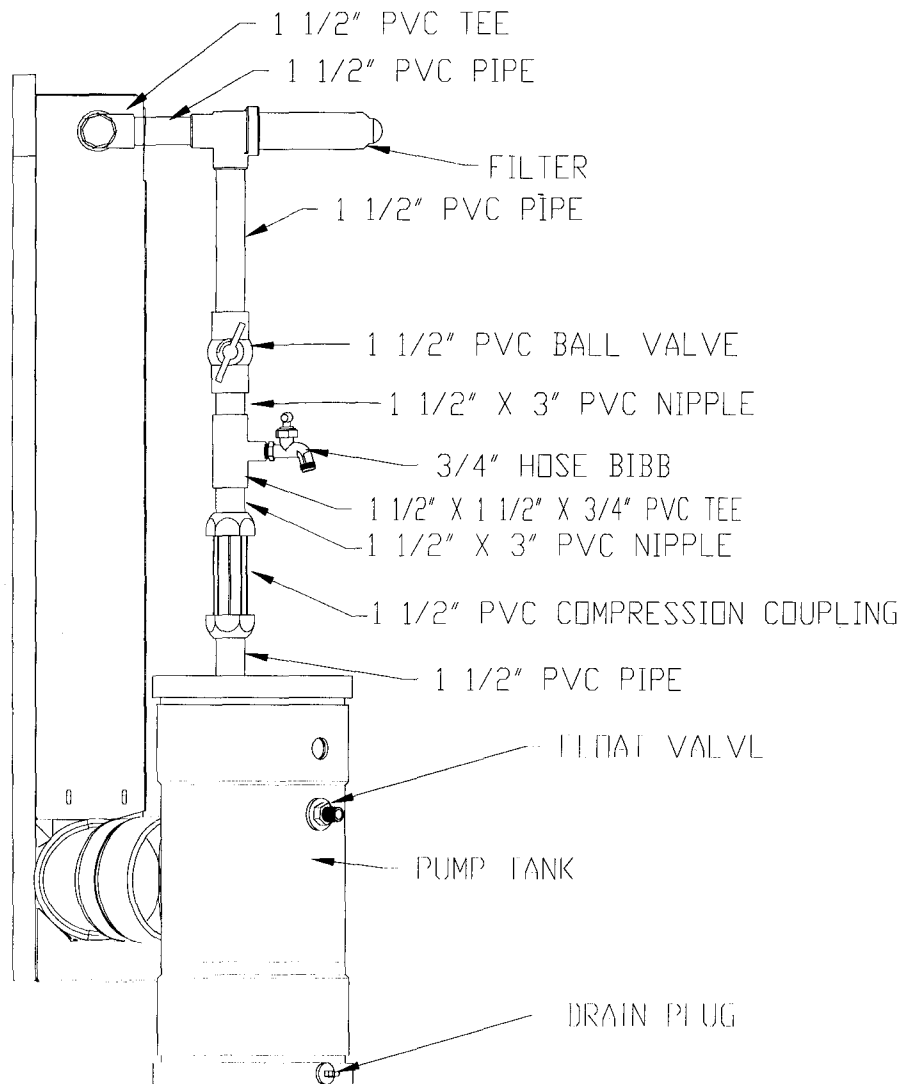
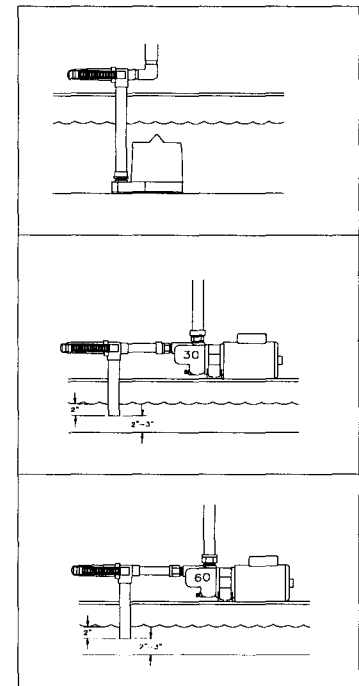

Figure 26



V. Exploded View

Bill of Material					
Common Parts					
1	Top Stringer	By Others	9	System End Cover – Left Seal	By Height
2	Bottom Stringer	By Others	10	System End Cover - Right	By Height
4	CTP Pipe Bracket	670273	11	6" Pad	As Req.
5	Pipe, 8" – 12" Long	512111	16	1 1/2" Slip Coupling	991535
6	8" Pipe Cap W/Connector	991790	17	Pipe Hanger	512009
8	Pad Support Joint Cover	512222	18	Top Cover Connector ss	511461
5 Foot System					
3	Pipe 8" x 60" Marked	512098	13	5' Top Cover	511485
7	Drip Collector & Pad Supt-60"	512200	14	5' Top Cover Support	512001
12	5' Pipe Cover	512058	15	Distribution Pipe-60X.125	512100
10 Foot System					
3	Pipe 8" x 120" Marked	512099	13	10' Top Cover	511490
7	Drip Collector & Pad Supt-120"	512221	14	10' Top Cover Support	512000
12	10' Pipe Cover	512063	15	Distribution Pipe-120X.125	512101

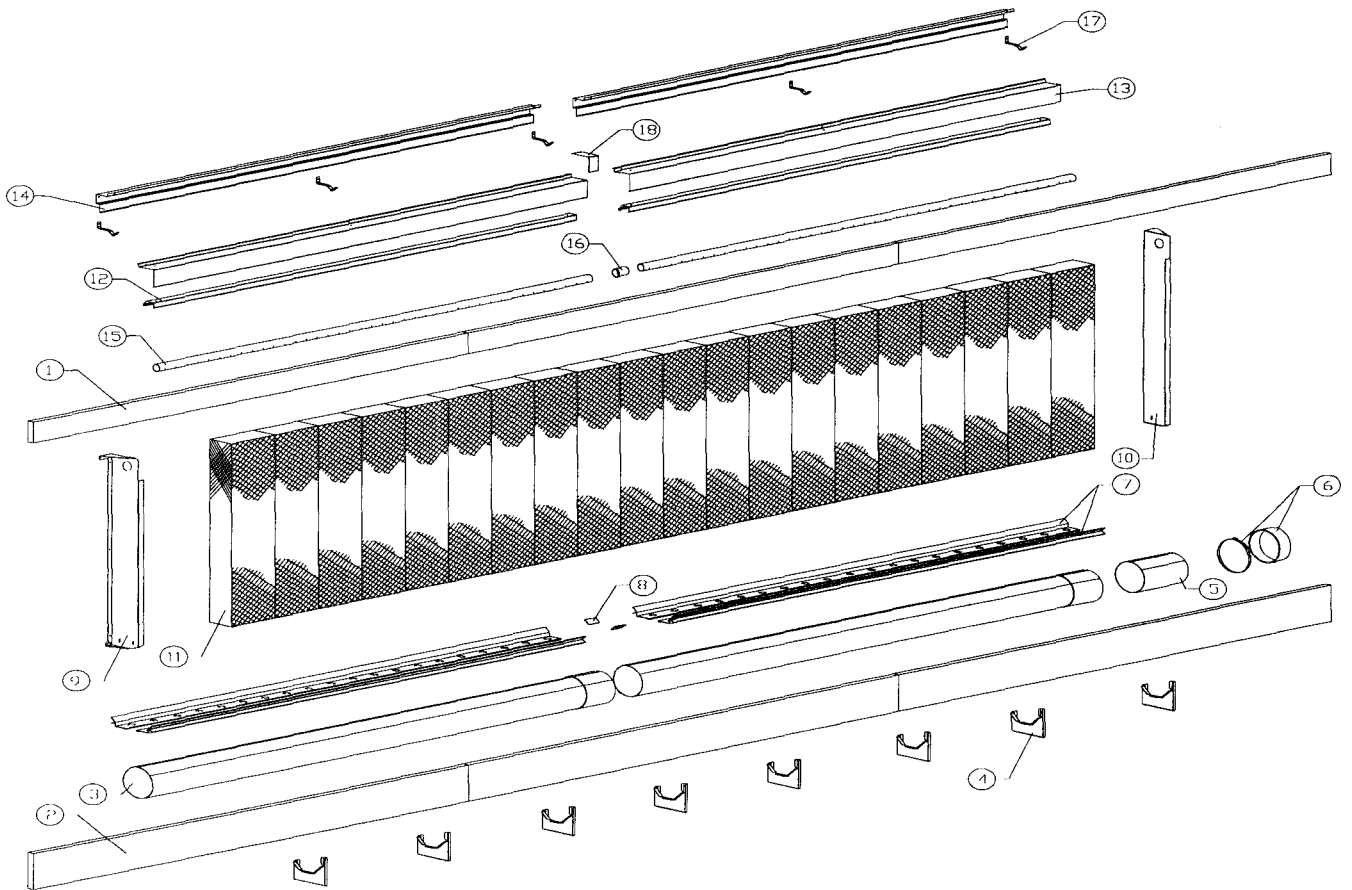

Figure 27

VI. 8 Inch PVC Pump Tank Kit

Figure 28

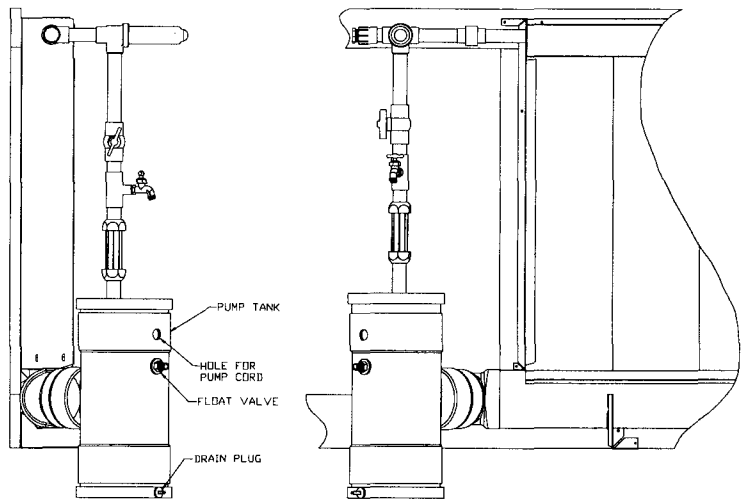
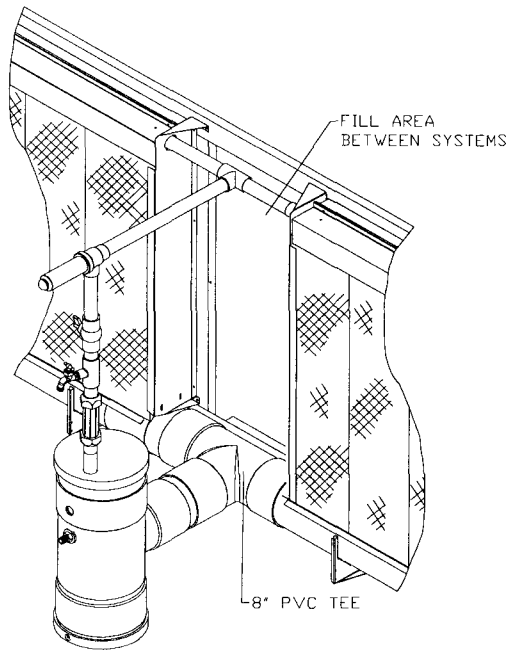
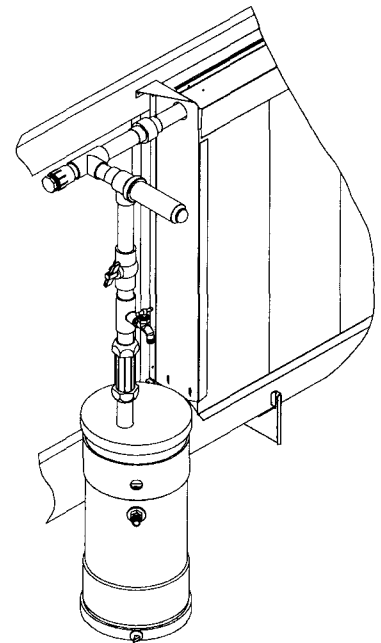

Figure 29

Figure 30



VII. PT50-OTP 50 Gallon Pump Tank Kit

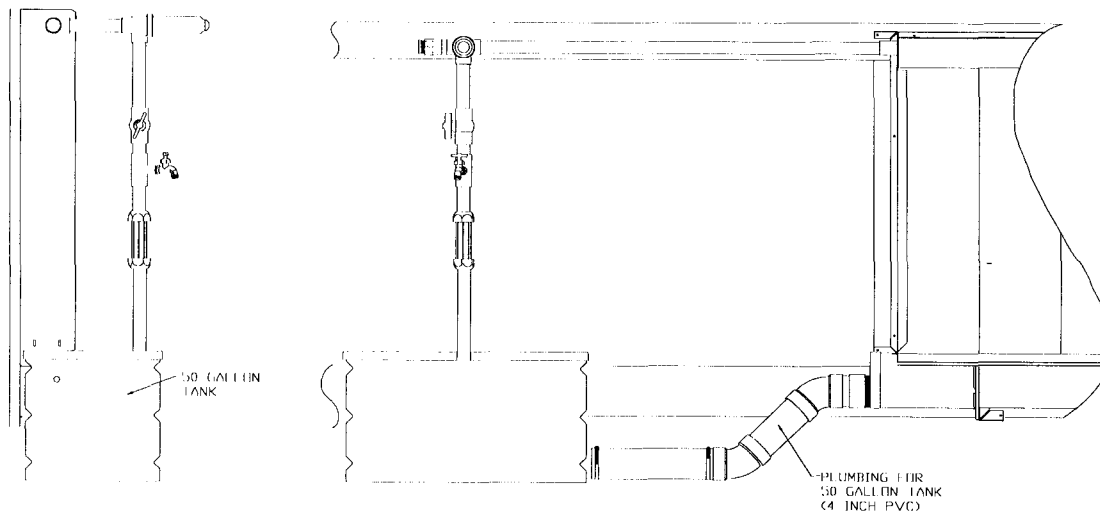

Figure 31

VIII. Start Up and Testing

- A) Test Water – Make up water should be tested for Ph level and soluble salts. Ph must be between 6 and 9 and salt concentrates below 40,000 ppm. See “Pad Care” Section X.
- B) Float Valve – Open the water supply line to the pump tank. Adjust the float valve so the water shuts off before the water level in the 8 inch pipe reaches the bottom of the pad.
- C) Pump – **Prime the pump** (#30 and #60) per instructions received with the pump.
- D) Flush the system to clean out all accumulated debris as follows:
 - 1. Open the flow valve. Close the clean out valve.
 - 2. Be sure pump is primed prior to operation. Run power to pump and let the svstem flush out
- E) Turn on the pump and be sure the water is flowing from all holes in the distribution pipe. Clean out any holes that are not spraying water.
- F) Remove a section of the top cover and adjust the flow valve until water sprays approximately 12 inches in the air. Replace the top cover section and your system is ready for operation.

NOTE: Temperature in a greenhouse that is empty will be considerably higher than a greenhouse with plants as the plants assist cooling by their transpiration.

IX. Maintenance

A regular maintenance schedule should be kept up to keep your Kool Cel system operating at peak efficiency and to **maximize the life of the system**.

- A) A visual check should be made whenever you’re in the area of the pad:
 - 1) Check for dry spots on the pad.
 - 2) Check for algae and scale on pads; See “Pad Care,”
- B) During the cooling season, when the pad is in operation:
 - 1) Weekly
 - a) Clean out strainer to prevent possible damage to pump. This may need to be done twice a week.
 - b) Clean out sediment plugs at the ends of system (Remove plugs and drain into a bucket with system pump off; replace plugs.)
 - c) Drain the sump to remove sediment, usually every two to four weeks. In areas with extremely high salt concentrates, this should be done weekly to lower salt concentrates in the sump. (Close the valve, connect hose to the hose bibb, open hose bibb and turn on the pump. Remove the drain plug from the tank to remove the remaining water.)
 - 2) Monthly
 - a) Inspect the complete system:
 - 1) Check for leaks and repair
 - 2) Check bleed-off connection to insure bleed off is occurring at all times.
 - 3) Check the strainer from the downspout in the sump – replace if necessary.
 - b) Test water for Ph level, (make up water and sump water) See “Pad Care” Section VIII.

C) Start and End of Cooling Season

1. At the end of the season, drain the pump and piping system to avoid damage caused by rust and impure particles in the water. If the system is outside the building, you must drain and remove the pump to avoid freeze damage.
2. To restart the system in the spring, follow the "Start up and Testing" procedure (VIII).
3. Inspect all parts and pads and replace any damaged or worn parts. See parts list and drawings on appropriate page or exploded drawing on page 12.

X. Pad Care

Kool-Cel pads are very durable and long lasting. To maximize the life of your pads and keep the efficiency of the original installation, review the following items and take necessary action to correct any conditions that may be detrimental to the pad.

- A) Ph of recirculating water** (from sump) must be maintained between 6 and 9 (7 is pure water). If these limits are exceeded, the stiffening agents in the pad will leach out and destroy the pad. Water containing acids to a degree that the Ph is below 6.0 aromatic hydrocarbons, or wetting and dispersing agents, such as phosphates, can be harmful to the pad.
- B) Hard water** resulting in Calcium Carbonate deposits on the pad is not harmful, but should be kept within limits. The well known Longelier Formula can help to approximate the Ph above which the scaling will appear. The help of a good water treatment expert is advisable if any hardness problems are encountered.
- C) Sodium Chloride** (salt water) concentrate above 50,000 ppm (approx.) will deposit salt on the pad and reduce air flow. Keep salt concentrates below 50,000 ppm in recirculating water and below 40,000 ppm in make-up water.
- D) Algae** will grow on any surface that is wet and exposed to sunlight. To help prevent algae build up, follow these tips:
 - 1) Do not draw make-up water from an open pond. Use well water or chlorinated water from city systems.
 - 2) Cover the sump to avoid exposure to sunlight and airborne particles, and to keep animals from drinking it.
 - 3) Keep the fans running after the pump is shut off to dry the pads, thus killing the algae spores left on the pad.
 - 4) Isolate the water make-up system from any other system that may carry fertilizers which would enhance algae growth.
 - 5) If algae persists, use a swimming pool water algaecide non-chlorine, chloride (tablet type) in the sump about $\frac{1}{4}$ the concentrate suggested for pools.
- E) Airborne dust and bugs** do not seem to clog the air flow passages of Kool-Cel. When the system is running this clogging washes away.
- F) When Kool-Cel is installed** within reach of poultry or livestock it should be guarded. To guard from poultry birds a (10 x 14) mesh guard approximately 8" –12" from the pad and the full length of the system should be provided up to approximately 3' from the birds' feet. The pad should be protected from livestock with a full heavy gage wire screen approximately 2" x 2" mesh and placed at least 6" from the pad.
- G) Bleed-Off** – Since the water is continuously evaporating and being replaced by fresh water, the salts and minerals are left behind in the re-circulating water. As these impurities become concentrated, they build up in the pads unless steps are taken to prevent this. To reduce the build up of deposits and scale, a bleed-off of from 1 to 2 percent of the recirculating water is usually required. This is particularly true in areas that have a high mineral content in the water. The required bleed-off is provided by the bleed-off fitting in the plug.

TERMS AND CONDITIONS OF SALE

ACCEPTANCE All orders and sales are subject to written approval and acceptance by an executive officer of Acme Engineering & Manufacturing Corporation at Muskogee, Oklahoma, (the "Company") and are not binding on the Company until so approved.

DELIVERY All shipping and delivery dates are estimated only. No delays in delivery will subject the Company to any costs, damages or fees for late delivery. Delivery of the products herein specified shall be made F.O.B. point of shipment, unless otherwise stated. The Company shall not be liable for delay due to causes beyond its reasonable control, such as Acts of God, acts of the purchaser, acts of civil or military authorities, priorities, fires, strikes, floods, epidemics, war, riots, delays in transportation, car shortages, and inability, due to reasons beyond its reasonable control, to obtain necessary labor, material, or manufacturing facilities. In the event of such a delay, the date of delivery shall be extended for a period equal to the time lost by reason of the delay.

TERMS OF PAYMENT If, in the judgment of the Company, the financial condition of the purchaser at any time does not justify continuation of manufacture or shipment on the terms of payment specified, the Company may require full or partial payment in advance.

Pro rata payments shall become due as shipments are made. Each shipment or delivery shall constitute a separate sale, and the default of any shipment or delivery shall constitute a separate sale, and the default of any shipment or delivery shall not vitiate the contract as to other shipments or deliveries.

PRICE ADJUSTMENT Prices are subject to change until the Purchaser's order has been accepted by the Company.

SALES AND SIMILAR TAXES The Company's prices do not include sales, use, excise, or similar taxes. Consequently, in addition to the price specified herein, the amount of any present or future sales, use, excise,

or other similar tax applicable to the sale of the product herein shall be paid by the Purchaser, or in lieu thereof the Purchaser shall provide the Company with a tax exemption certificate acceptable to the taxing authorities.

CANCELLATION Any contract resulting from the Purchaser's order may be canceled by the Purchaser only by negotiations and upon payments of reasonable cancellation charges which will take into account expenses already incurred and commitments made by the Company.

DESIGN CHANGES The Company reserves the right to make changes in design, improvements and additions in and to its products any time without imposing any liability or obligations to itself to apply or install the same in any product manufactured by it.

TITLE The title and right of possession of the products sold herein shall remain with the Company and such products shall remain personal property until all payments herein (including deferred payments whether evidenced by notes or otherwise) shall have been made in full in cash and the Purchaser agrees to do all acts necessary to perfect and maintain such right and title in the Company.

PRICE ADJUSTMENTS AND PROTECTION Prices on products manufactured by the Company are firm for shipment up to four months from the date of the original order entry. Such prices are subject to adjustment if shipment is made after four months and up to ten months from the date of the original order entry, if products are shipped ten months from the date of the original order entry, prices will be adjusted to the price in effect at the time of shipment automatically. All complete component accessory material manufactured by others and furnished with the Company's products such as motors, drives, vibration equipment, controls or other completely assembled component structures, are subject to adjustment to the price at time of shipment regardless of the date of original order entry.

SAFETY ACCESSORIES The Company manufactures products designed to serve multiple applications and offers a wide range of safety equipment, including guards and other devices, as may be required to meet customer specifications. Without exception, the Company recommends that all orders include applicable safety devices. Products ordered without applicable safety devices is clearly the responsibility of the Purchaser. Further, the Purchaser warrants that it has determined and acquired any and all safety devices required for products sold by the Company. Weather covers and guards for motor and V-belt drives, couplings, shafts and bearings, along with inlet and outlet screens, are optional accessories noted in the price list.

GOVERNING LAW The rights, obligations and remedies of Purchaser and the Company, the interpretation of these terms and conditions and the sale of products by the Company shall be governed by Oklahoma law, without regard to any principles of conflict of laws.

ARBITRATION Any dispute arising under or in connection with these terms and conditions or the sale of products shall be settled by binding arbitration administered by the American Arbitration Association under its Commercial Arbitration Rules, and judgment on the award rendered by the arbitrator may be entered in any court having jurisdiction thereof. The dispute shall be resolved by one neutral arbitrator who shall have no affiliation with either Purchaser or the Company and shall be selected by the American Arbitration Association office in Dallas, Texas. The arbitration proceedings shall be held in Muskogee, Oklahoma.

APPLICABLE DOCUMENTS The agreement between the Company and the Purchaser relating to the products includes these terms and conditions of sale, any applicable installation and maintenance instructions provided by the Company and any terms appearing on the Company's quotation, sales order acknowledgment and invoice.

WARNING Acme products are designed and manufactured to provide reliable performance but they are not guaranteed to be 100% free of defects. Even reliable products will experience occasional failures and this possibility should be recognized by the Purchaser and all End Users. If these products are used in a life support ventilation system where failure could result in loss or injury, the Purchaser and all End Users should provide adequate back-up ventilation, supplementary natural ventilation or failure alarm system, or acknowledge willingness to accept the risk of such loss or injury.

WARNING DO NOT use in HAZARDOUS ENVIRONMENTS where fan's electrical system could provide ignition to combustible or flammable materials unless unit is specifically built for hazardous environments. Comply with all local and national safety codes including the National Electrical Code (NEC) and National Fire Protection Act (NFPA).

CAUTION Guards must be installed when fan is within reach of personnel or within seven (7) feet (2.134 m) of working level or when deemed advisable for safety.

DISCLAIMER The Company has made a diligent effort to illustrate and describe the products accurately in all Company literature; however such illustrations and descriptions are for the sole purpose of identification and do not express or imply any warranty.

LIMITED WARRANTY

WARRANTY AND DISCLAIMER: the Company extends this limited warranty to the original purchaser and warrants that products supplied by the Company, shall be free from original defects in workmanship and materials for two years from date of shipment (except for the warranty periods noted for products listed below), provided same have been properly handled, stored, installed, serviced, maintained and operated. This warranty shall not apply to products which have been altered or repaired without the Company's express authorization, or altered or repaired in any way so as, in the Company's judgment, to affect its performance or reliability, nor which have been improperly installed or subjected to misuse, negligence, or accident, or incorrectly used in combination with other substances. The Purchaser assumes all risks and liability for results of use of all products.

Evaporative cooling pads are warranted to be free of defects in materials and workmanship for a period of two years from date of shipment provided same have been properly handled, stored, installed, serviced, maintained and operated; and further, not subjected to excessive heat, corrosive agents or chemicals, or mechanical abuse that may cause tearing, crushing or undue deterioration, nor used on a system or in a manner other than that for which it was designed as explained in the product literature.

The following products are warranted to be free of defects in materials and workmanship for the periods shown from date of shipment: Acme's exclusive duplex split pillow block bearings and shaft five years, belts one year, Polyethylene tubing 90 days, AIR40 Heater warranty one year, AIR40 Emitter warranty three years and DDP fan lifetime warranty on its propeller, cone, and housing.

LIMITATION OF REMEDY AND DAMAGES: All claims under this warranty must be made in writing and delivered to P. O. Box 978, Muskogee, Oklahoma, 74402, within 15 days after discovery of the defect and prior to the expiration of two years from the date of shipment by the Company of the product claimed defective, and Purchaser shall be barred from any

remedy if Purchaser fails to make such claim within such period.

Within 30 days after receipt of a timely claim, the Company shall have the option either to inspect the product while in Purchaser's possession or to request Purchaser to return the product to the Company at Purchaser's expense for inspection by the Company. The Company shall replace, or at its option repair, free of charge, any product it determines to be defective, and it shall ship the repaired or replacement product to Purchaser F.O.B. point of shipment; provided, however, if circumstances are such as in the Company's judgment to prohibit repair or replacement to remedy the warranted defects, the Purchaser's sole and exclusive remedy shall be a refund to the Purchaser of any part of the invoice price, paid to the Company, for the defective product or part.

The Company is not responsible for the cost of removal of the defective product or part, damages due to removal, or any expenses incurred in shipping the product or part to or from the Company's plant, or the installation of the repaired or replaced product or part.

The warranties set forth above do not apply to any components, accessories, parts or attachments manufactured by other manufacturers; such being subject to the manufacturer's warranty, if any. To the extent not prohibited by the manufacturer's warranty, the Company shall pass through to Purchaser such manufacturer's warranty.

THE COMPANY'S WARRANTY IS IN LIEU OF ALL OTHER WARRANTIES, EXPRESS OR IMPLIED, ARISING BY LAW OR OTHERWISE, INCLUDING WITHOUT LIMITATION THE IMPLIED WARRANTIES OF MERCHANTABILITY AND FITNESS FOR A PARTICULAR PURPOSE, WHICH ARE HEREBY EXPRESSLY DISCLAIMED AND WAIVED. THIS WARRANTY CONSTITUTES THE COMPANY'S SOLE AND EXCLUSIVE WARRANTY FOR DEFECTIVE GOODS AND PURCHASER'S SOLE AND EXCLUSIVE REMEDY FOR DEFECTIVE PRODUCTS.

No employee, agent, dealer, or other person is authorized to give any warranties on behalf of the Company or to assume for the Company any other liability in connection with any of its products except in writing and signed by an officer of the Company.

REPLACEMENT PARTS If replacement parts are ordered, purchaser warrants that the original components in which these replacement parts will be placed are in satisfactory working condition, and

when said replacement parts are installed, the resultant installation will operate in a safe manner, at speeds and temperatures for which the original product was purchased.

TECHNICAL ADVICE AND RECOMMENDATIONS, DISCLAIMER: Notwithstanding any past practice or dealings or any custom of the trade, sales shall not include the furnishing of technical advice or assistance or system design. Any such assistance shall be at the Company's sole option and may be subject to additional charge.

The Company assumes no obligation or liability on account of any recommendations, opinions or advice as to the choice, installation or use of products. Any such recommendations, opinions or advice are given and shall be accepted at Purchaser's and End User's risk and shall not constitute any warranty or guarantee of such products or their performance.

LIMITATION OF LIABILITY The cumulative liability of the Company to the Purchaser and any other persons for all claims in any way relating to or arising out of the products, including, but not limited to, any cause of action sounding in contract, tort, or strict liability, shall not exceed the total amount of the purchase price paid for those products which are the subject of any such claim. This limitation of liability is intended to apply without regard to whether other provisions of this agreement have been breached or have proven ineffective even if the Company has been advised of the possibility of such claims or demands. In no event shall the Company be liable to the Purchaser or any other person for any loss of profits or any incidental, special, exemplary, or consequential damages for any claims or demands brought by the Purchaser or such other persons.

INDEMNITY The Company's maximum liability to Purchaser and to any end user is as set forth above. The Company makes no warranty to anyone for any products not manufactured by the Company and shall have no liability for any use or installation of any products (whether manufactured by the Company or other manufacturers) not specifically authorized by this sale. Purchaser acknowledges various warnings by the Company regarding the products and its installation and use. If the Company incurs any claims, lawsuits, settlements, or expenses (including attorney fees) for any loss, injury, death or property damage including, but not limited to, claims arising out of the Purchaser's or any end user's installation or use of the products, the Purchaser shall indemnify and hold the Company harmless.



ACME ENGINEERING AND MANUFACTURING CORPORATION
P.O. Box 978
Muskogee, Oklahoma 74402
Telephone 918/682-7791
Fax 918/682-0134
www.acmefan.com